

SPINNING REEL 1500C

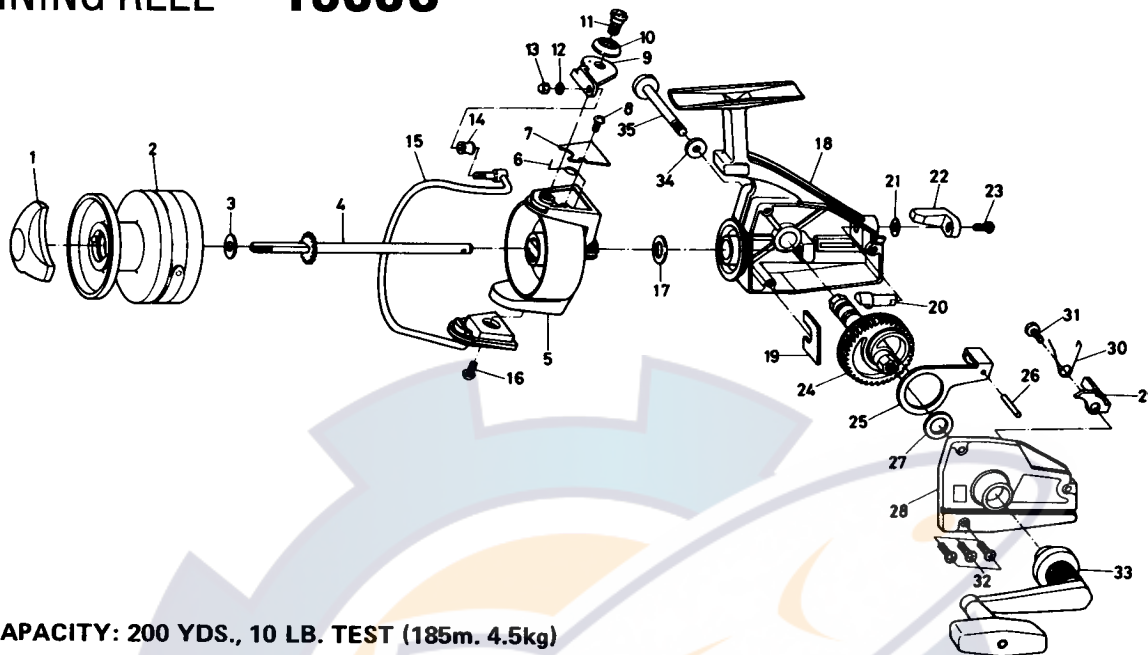

LINE CAPACITY: 200 YDS., 10 LB. TEST (185m. 4.5kg)

Key No.	Parts No.	Parts Name	Price Per Piece	Key No.	Parts No.	Parts Name	Price Per Piece
1	6-740-2102	Drag knob	\$2.00	19	6-632-6601	Pinion retainer	\$.10
2	6-731-1401	Spool assembly	8.10	20	6-460-7022	Anti-reverse cam	.20
3	6-371-8331	Spool washer	.10	21	6-150-1751	Anti-reverse lever washer	.10
4	6-710-2411	Main shaft	.70	22	6-540-8001	Anti-reverse lever	.15
5	6-735-1001	Rotor	2.75	23	6-351-1801	Anti-reverse lever screw	.10
6	6-141-7811	Bail spring	.10	24	6-412-2701	Drive gear	1.75
7	6-632-6501	Bail spring cover	.15	25	6-480-7501	Oscillating slider	.40
8	6-351-1801	Bail spring cover screw	.10	26	6-121-1211	Oscillating slider pin	.10
9	6-230-8811	Arm lever	.60	27	6-371-2820	Drive gear washer	.10
10	6-130-3201	Bail holder cap	.10	28	6-705-1308	Body cover	1.90
11	6-363-1901	Arm lever screw	.30	29	6-110-7201	Anti-reverse claw	.20
12	6-160-0121	Bail washer	.10	30	6-142-3951	Anti-reverse claw spring	.10
13	6-341-0801	Bail nut	.20	31	6-351-7701	Anti-reverse claw screw	.10
14	6-250-1011	Line roller	.40	32	6-351-5901	Body cover screw	.10
15	6-725-1031	Bail	1.75	33	6-745-2311	Handle	3.45
16	6-351-6601	Bail holder screw	.10	34	6-372-3501	Handle washer	.10
17	6-372-8600	Rotor washer	.10	35	6-361-9611	Handle screw	.25
18	6-700-1315	Body	4.25				